



**GSZ** 3-phase  
50Hz

High head - high capacity  
- for professional use

4-pole motor for an increased lifetime and greater convenience.



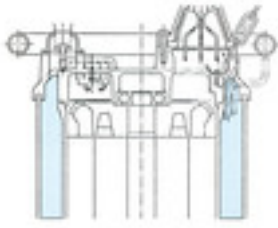

## Water jacket

Inner and outer motor casing - flow-through-design - perfect cooling under dry-run-conditions

## Rugged

A special-steel impeller and suction plate have greatly increased the pump's life. The casing is designed to have wide passing area, thorough thickness and antiabrasion material. 4-pole motor used to achieve a simple structure that demonstrates excellent durability and versatility. Spiral structure, marvelously facilitates the passage of sand, soil, sludge, or slime - without clogging.



## Components:

001 Cable	046 Air valve
006 Cable entrance	050 Motor cover
020 Pump casing	052A Upper bearing
021 Impeller	052B Lower bearing
022 Suction plate	053. Miniature protector
023 Strainer	054 Shaft
025 Mechanical seal	055 Rotor
026A Oil sealing	056 Stator
026B Oil sealing	060 Bearing housing
026C Labyrinth ring	062 Bearing cover
027 Seal casing	064 Motor casing
029 Oil casing	065 Jacket
035 Oil plug	071 Shaft sleeve
036 Lubricant	072 Eye bolt

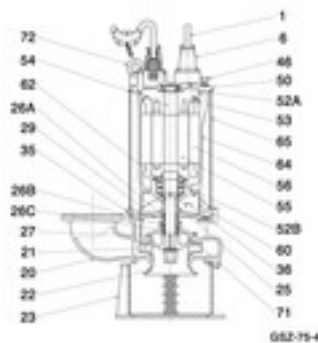

## Specifications:

Model	Colour code curve	Bore mm	Motor output kW	Rated current A	Head max. m	Capacity max. l/min	Dry weight kg w/o cable	Max. solid handling ø mm	Pressure resistance max. m	Cable length m
GSZ2-75-4	1	250	75,0	146,0	52,0	12500	1140,0	25	20	20
GSZ2-75-4L	2	250	75,0	146,0	38,0	17500	1200,0	25	20	20

ø Discharge bore mm		250		
Pumping Fluid	Type of Fluid	Spring water, Rain water, Ground water, Sand carrying water		
	Temperature	0-40°C		
Pump	Components	Impeller	Closed type impeller	
		Shaft Seal	Double mechanical seal	
		Bearings	Shielded ball bearings	
	Material	Impeller	Stainless steel casting DIN X5CrNi18-10, Chromium iron casting	
		Casing	Grey iron casting EN-GJL-200	
	Shaft Seal	Silicon carbide in oil bath		
Motor	Type, Poles		Induction motor, 4 poles, IP68	
	Motor Protector (built-in)		Miniature protector	
	Insulation		Insulation class E	
	Lubrication		Turbine oil (ISO VG32)	
	Phase / Voltage		3-phase / 400V / 50Hz / s.d.	
	Material	Casing	Grey iron casting EN-GJL-200	
Shaft		Stainless steel EN-X30Cr13		
Cable		Rubber, NSSHÖU		
Discharge Connection		JIS 10K Flange		

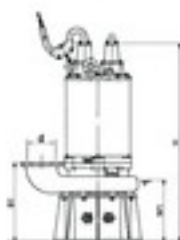
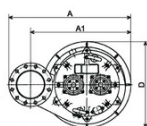
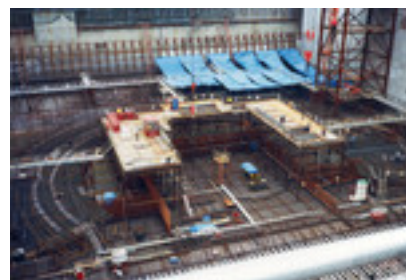
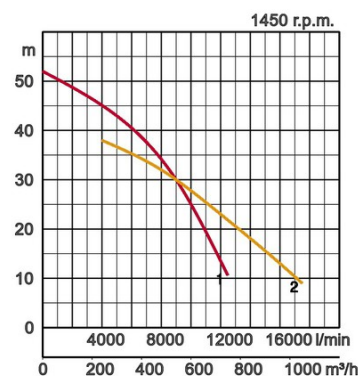

## Dimensions in mm:

Model	d	A	A1	B1	D	H	W1
GSZ2-75-4	250	1050	850	655	708	1733	510
GSZ2-75-4L	250	1050	850	700	739	1778	730

W1: lowest running water level

In the event of abrasive and corrosive utilization, stronger wear and tear will take place naturally in certain components. In this regard, please pay attention to our website [www.tsurumi.eu/english/applications.htm](http://www.tsurumi.eu/english/applications.htm).



Contributing to World-wide Prosperity and Understanding through Worker- and Environment-friendly Production.

Designed for increased productivity through fully integrated streamlined production systems, Tsurumi's factory in Kyoto (Japan) features a production capacity of a full 1 million pumps per year. Large-scale modern R&D facilities offer optimum conditions for experimenting and testing of even super-large pumps and for developing new products to expand the possibilities and applications of pumps. To provide optimum conditions for our main asset, our workers, as well as for the environment, special emphasis is placed on optimized working conditions with airconditioning, minimized dust and exhaust gas emission, comprehensive recycling and waste recovery.

## Tsurumi (Europe) GmbH

Wahlerstr. 10  
D-40472 Düsseldorf  
Tel.: +49 (0)211-4179373  
Fax: +49 (0)211-417937-480  
Email: [sales@tsurumi.eu](mailto:sales@tsurumi.eu)  
[www.tsurumi.eu](http://www.tsurumi.eu)

We reserve the right to change specifications and designs herein for improvement without prior notice. Our pumps are for professional use only. In the event that Tsurumi (Europe) GmbH have, in exceptional cases taken over, a manufacturer's warranty, this entitles the enduser to assert remedy free of charge against Tsurumi (Europe) GmbH due to any defect to the product occurring during the guarantee period (see below), also then when the warranty claims against the seller do not or no longer exist. In the event of malfunction, which is attributable to the improper handling by the enduser, no guarantee claim shall arise. Further claims shall not result from the warranty, unless if something to the contrary has explicitly been determined. The decision as to whether remedy is effected by way of replacement or repair shall be at the choice of Tsurumi (Europe) GmbH. The claims shall be time barred after a period of three months after expiry of the guarantee period, however, not before expiry of the warranty period which is valid towards the seller. In the event of doubt, the warranty period shall correspond with the warranty period which is valid between the end-user and his seller.



con-CSZ-EN

